

S. J. CHAPMAN.
Bale-Tie.

No. 196,433.

Patented Oct. 23, 1877.

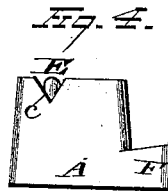
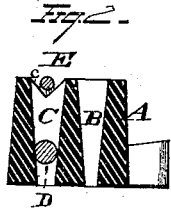
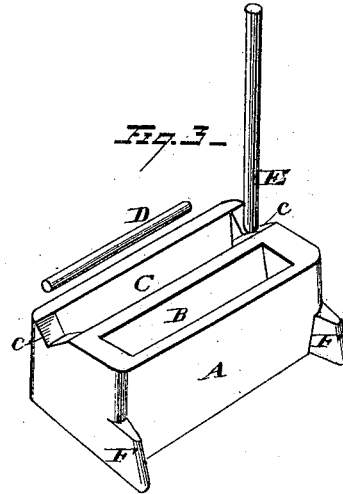
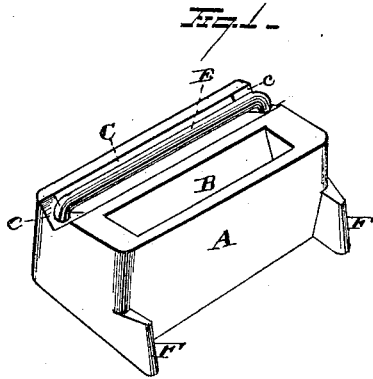

WITNESSES

Edw. S. K. Hougham,
A. M. Bright.

INVENTOR

S. J. Chapman,
By *S. S. Eggett & S. S. Eggett*
ATTORNEYS.

UNITED STATES PATENT OFFICE.

SAMUEL J. CHAPMAN, OF CHARLESTON, SOUTH CAROLINA, ASSIGNOR OF ONE-HALF HIS RIGHT TO DANIEL S. SILCOX, OF SAME PLACE.

IMPROVEMENT IN BALE-TIES.

Specification forming part of Letters Patent No. **196,433**, dated October 23, 1877; application filed July 30, 1877.

To all whom it may concern:

Be it known that I, SAMUEL J. CHAPMAN, of Charleston, in the county of Charleston and State of South Carolina, have invented certain new and useful Improvements in Bale-Ties; and I do hereby declare the following to be a full, clear, and exact description of the invention, such as will enable others skilled in the art to which it pertains to make and use it, reference being had to the accompanying drawings, which form part of this specification.

My invention relates to certain improvements in ties for bale-bands; and consists in the construction of a tie, as is hereinafter set forth and claimed.

Referring to the drawings, Figure 1 is a view in perspective of my improved bale-tie. Fig. 2 is a transverse section of the same. Fig. 3 represents the tie preparatory to receiving the fastener, and Fig. 4 is an end view of the tie with the fastener locked in place.

The tie A may be made of any suitable material, with the two through-slots, B and C, each wedge-shaped in cross-section. The one (C) in which the free end of the bale-band is to be locked is provided with a fastener, D, which may be of any desired character, either a wedge, or roller, or pawl, and the same whether made plain, corrugated, or fluted, and made of any suitable material.

Its object is to lock the band against withdrawal by the frictional resistance or bite imposed upon the band between the fastener on the one side, and the inclined wall of the slot on the other side, as the band is attempted to be withdrawn.

The upper edge of the tie-body, forming the end walls of this slot C, at its larger opening is made countersunk, or with suitable depressions *c*. These depressions or recesses may be of any desired form or size, the object being, broadly, to provide such a construction as will allow the guard-piece or cover E to be protected from injury or displacement.

It is immaterial, also, of what special material or character this guard or cover may be, provided only it locks the fastener against removal from its working slot, and is adapted to be protected within the depressions *c*.

This guard-piece or cover is so located as to

allow the band to pass to either or to only one side of it, as preferred, in the passage of the band out through the larger opening of the slot; and by having the top surface of the guard or cover flush or in line with the surface of the main body of the tie, it is prevented from receiving blows, injury, or of being subjected to such conditions as would tend to dislocate or harm it. At the same time, it constantly guards the fastener against removal, whether the band is inserted in the slot or not.

Formed on the side of the tie-body are the two spur-projections, F, which are placed, one on either longitudinal end of the tie, thus allowing the bale-band to pass between them, and lie flat against the side of the tie, as is usual, without interference from the spurs. The object of these latter is to prevent the tie from displacement upon the bale; and as they catch or project into the bale, all sliding or slipping of the band thereon is prevented. They may be located at any suitable points on the tie, other than as shown, provided only they do not interfere with the band, as they should bear directly against the bale, and not be so located as to be obliged to have the band or hoop intervene between them and the bale.

Having fully described my invention, what I claim as new, and desire to secure by Letters Patent, is—

1. In a bale-tie, the guard-piece or cover locking in the band-fastener, and seated in depressions or recesses formed in the body of the tie, whereby the said guard or cover is protected against injury or displacement, substantially as described.

2. An automatic bale-tie constructed with two through-openings, in one of which is secured an automatic locking-bar, said tie provided with lugs projecting from one side thereof, said lugs being cast solid with the tie, substantially as described.

In testimony that I claim the foregoing I have hereunto set my hand this 25th day of July, 1877.

SAMUEL J. CHAPMAN.

Witnesses:

T. MOULTRIE MORDECAI,
O. L. LEGERTON.