

P. J. COUGLIZ.

SEWER.

No. 12,994.

Patented Jan. 5, 1855.

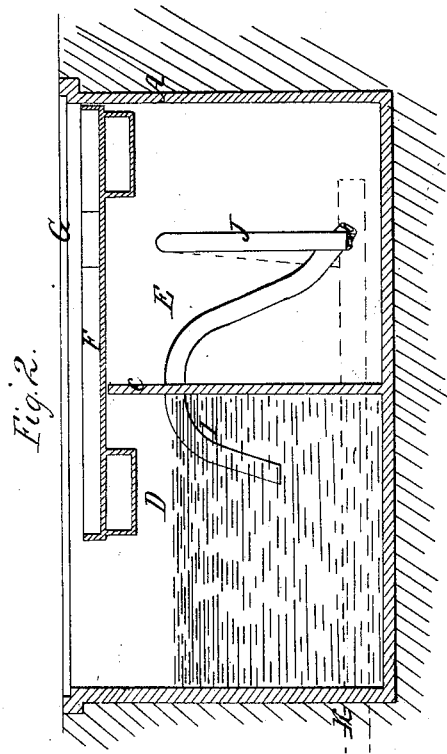
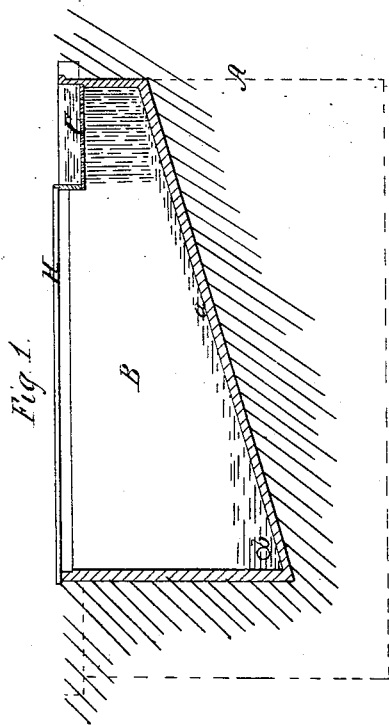
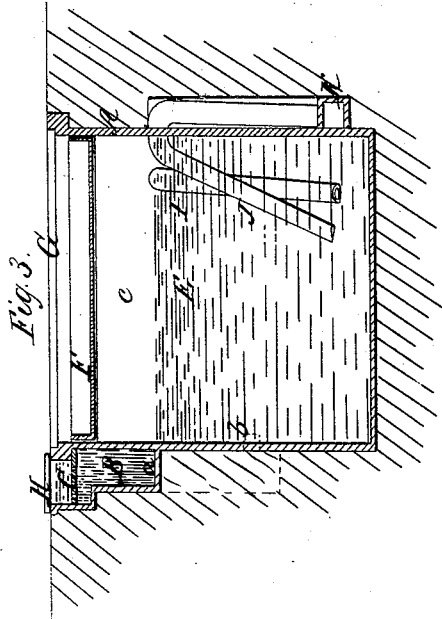

UNITED STATES PATENT OFFICE.

P. J. COOGAN, OF CHARLESTON, SOUTH CAROLINA.

ARRANGEMENT OF DRAINS FOR SEWERS.

Specification of Letters Patent No. 12,994, dated June 5, 1855.

To all whom it may concern:

Be it known that I, P. J. COOGAN, of Charleston, in the county of Charleston, and State of South Carolina, have invented a new and useful Improvement in Drains; and I do hereby declare that the following is a full, clear, and exact description of the same, reference being had to the annexed drawings, making a part of this specification, in which—

Figure 1, is a side view of the box or receiver which is sunk in the ground the induction passage on the side thereof being bisected vertically through its center. Fig. 2, is a transverse vertical section of the box or receiver. Fig. 3, is a longitudinal vertical section of ditto.

Similar letters of reference indicate corresponding parts in the several figures.

The nature of my invention consists in the employment of siphons, placed within a box or receiver constructed and arranged as will be presently shown and described, whereby the sewer or channel which extends from the box or receiver to the main sewer is prevented from being choked or stopped with sediment or impurities, and all unpleasant and unwholesome effluvia arising therefrom avoided.

A, represents a rectangular box or receiver, which may be constructed of any proper material and of any desirable size according to circumstances. Brick would most probably be generally used for the construction of the box or receiver A. At one side of the box or receiver there is a narrow induction chamber B, the bottom (*a*) of which is inclined as shown clearly in Fig. 1. At the upper part of the chamber B, at one end there is a grate C, and at the lower part of the chamber at the depressed or lower end of the inclined bottom (*a*) there is an aperture (*b*) through the side of the box or chamber A, see Fig. 1, and dotted lines in Fig. 2. The box or receiver A, is divided transversely by a partition (*c*) into two compartments D, E, as shown in Fig. 2. At the upper part of the box or receiver there is a pan F, and directly over the pan there is a lid or cover G, which is fitted snugly to the box or receiver. The upper end of the induction chamber B, is also provided with a lid or cover H. The compartment D, of the box or receiver A,

is provided with a siphon I, which passes through the partition (*c*) the longer leg of the siphon being in the chamber E, and reaching within a short distance of its bottom see Figs. 2 and 3. The compartment E, is also provided with a siphon J, which reaches nearly to the bottom of the compartment. The outer leg of this siphon is connected to an inclined passage K, at the lower part of one side of the box or receiver A, on its outer side, see Fig. 3, and dotted lines in Fig. 2. The passage K, communicates with a drain, or passage which conveys the water or liquid to the common sewer or to any proper place. The box or receiver A, is sunk in the ground, its top or cover G, being flush with its surface.

The water, slops, etc., is thrown upon the grate C, and falls upon the inclined bottom (*a*) of the chamber B. The bottom (*a*) in consequence of being quickly inclined or quite steep carries down all the sediment and heavy particles that the water may contain or hold in solution. The water, slops, etc., pass through the aperture (*b*) into the compartment D, the sediment and heavy matter will settle to the bottom of this compartment, and when the water or liquid reaches the upper end or surface of the bend or curve of the siphon I, the water or liquid will flow into the compartment E. And when the water or liquid reaches the upper end or surface of the bend or curve of the siphon J, the water will flow from the compartment E, into the inclined passage K.

By the above invention, it will be seen that all heavy matter will be prevented from entering the drain or passage K, because it will settle at the bottom of the compartment D, before the water or liquid will reach the upper surface of the bent or curve of the siphon I. This is important, for in the usual drains, the sediment and heavy matter often collects and chokes or stops the passage of the water, and consequently the sediment throws off an offensive and unwholesome effluvia which impregnates the atmosphere and is the fruitful source of disease.

My improvement is applicable in all cases where drains or sewers are employed and especially in cities. The lid or cover G, of the box or receiver is removed when required, and the sediment removed there-

from. The pan F, is intended to hold any
 purifying or disinfecting material, in order
 to insure the prevention of the escape of un-
 pleasant effluvia at the top of the box or
 5 chamber.

What I claim as new and desire to secure
 by Letters Patent, is,

The box or receiver A, provided with
 siphons I, J, and otherwise arranged, as
 shown for the purpose as set forth.

P. J. COOGAN.

Witnesses:

R. S. DURYEA,
 JOHN PHILLIPS.